

Technical data	operation when directly connected to chimney	operation when connected accumulation mass
Energy label	A+	A+
Operating data		
Nominal heat power	16 kW	----
Efficiency	> 80 %	----
Consumption of wood	4,5 kg/h	6 kg
Total heat output of the burning chamber	----	24 kW
Average heat output / heat accumulation time ⁵	----	2,4 kW / 8 h
Mass flow of flue gas	15,8 g/s	20 g/s
Required chimney pressure	12 Pa	12 Pa
Required amount of combustion air	40 m ³ /h	60 m ³ /h
Average flue gas temperature		
on the output	251 °C	403 °C
behind 3,6 m of ceramic accumulation system KMS 300 ¹	----	185 °C
Heat distribution		
fireplace insert	57–68 %	40 %
door glass (single / double)	43 / 32 %	43 / 32 %
additional accumulation mass	----	17–28 %
Information for ventilated builds		
Minimal grill area supply / outgoing	1400 / 1700 cm ²	1400 / 1700 cm ²
Minimum distance from insulated areas / floor	80 / 0 mm	80 / 0 mm
Reference insulation ² ceiling / back wall / side wall / floor	120 / 80 / 80 / 0 mm	120 / 80 / 80 / 0 mm
Calciumsilicate insulation ³ ceiling / back wall / side wall / floor	90 / 60 / 60 / 0 mm	90 / 60 / 60 / 0 mm
Information for non-ventilated builds (closed grills)		
Minimum radiant area ⁴	suitable	5 m ²
Minimum distance from insulated areas / floor	80 / 20 mm	80 / 20 mm
Reference insulation ² ceiling / back wall / side wall / floor	160 / 100 / 100 / 20 mm	160 / 100 / 100 / 20 mm
Calciumsilicate insulation ³ ceiling / back wall / side wall / floor	120 / 75 / 75 / 20 mm	120 / 75 / 75 / 20 mm
General technical information		
Total weight / lining weight	circa 536 / 175 kg	circa 536 / 175 kg
Burning chamber dimensions (width x depth)	1410 x 315 mm	
Combustion air connection	Ø 150 mm	
Use in non-ventilated accumulation builds according to craft rules	suitable	
Tested according to	EN 13229	
Meets values	BImSchV (Stufe2), 15a BvG, NS 3059	

1 Listed value from testing. For accurate results is evaluation of each system in the Ortnr / KOV program necessary

2 Mineral wool according to AGI-Q 132

3 Example SkamoEnclosure Board 225 kg/m³

4 Depends on accumulation period and material characteristics. Listed values calculated with average specific heat output = approx. 500 W/m²

5 Storage operation, one wood charge for storage duration, with closed construction and efficiency > 80%

HAKA 150/51h

Technical data
Version 09/2023

HAKA 150/51h liftdoor

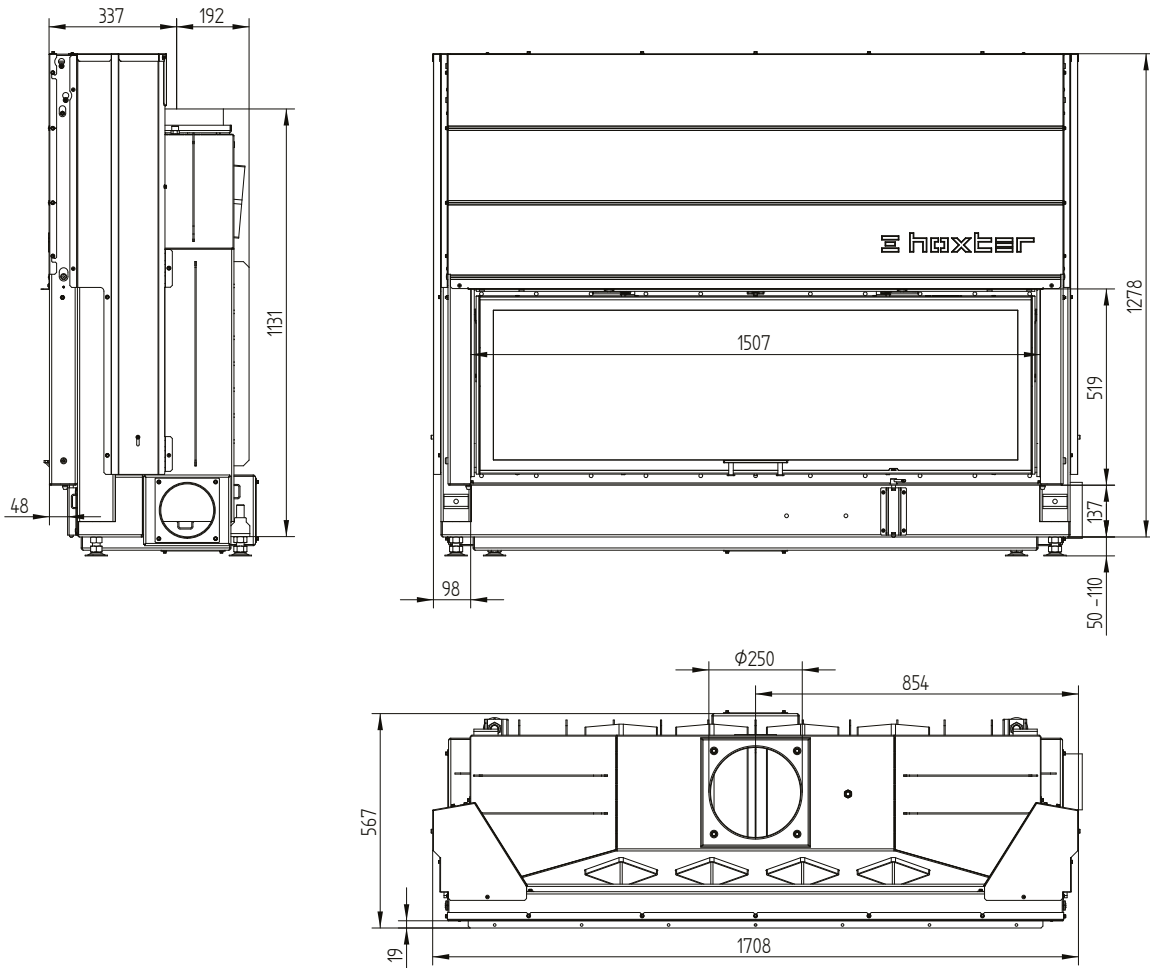

HAKA 150/51h

Technical data
Version 09/2023

Cover frame 150/51h liftdoor 4sides 50 mm 1 x 90° / air inlet

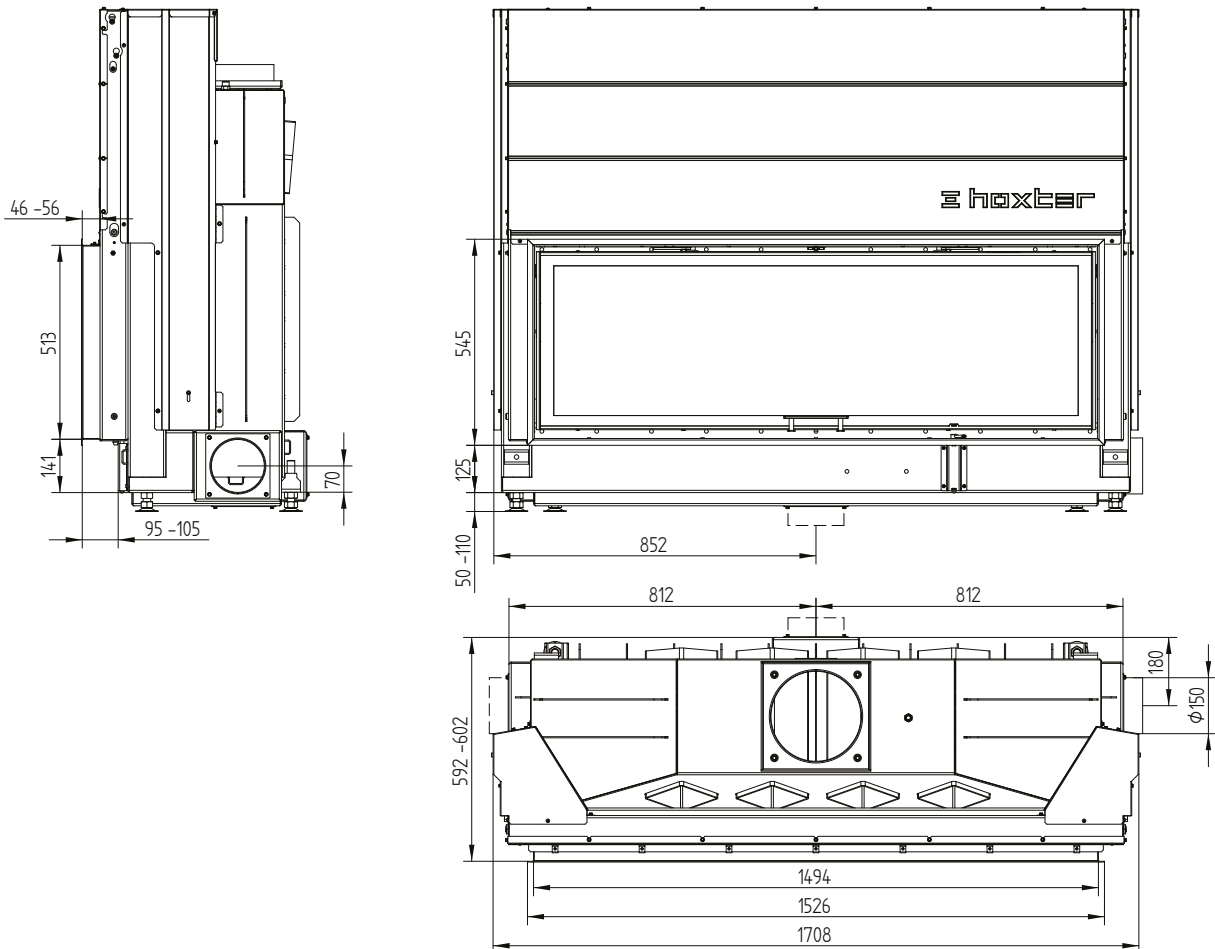

HAKA 150/51h

Technical data
Version 09/2023

Cover frame 150/51h liftdoor 4sides 80 mm 1 x 90°

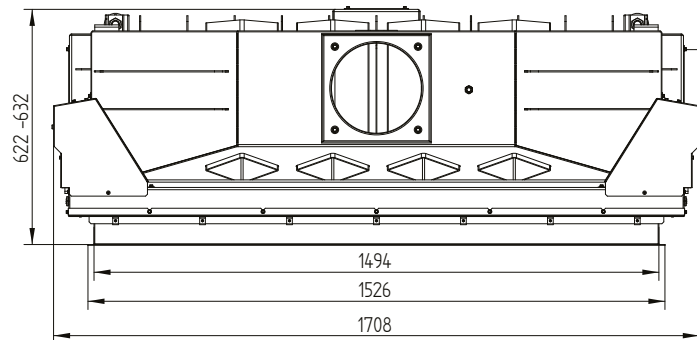
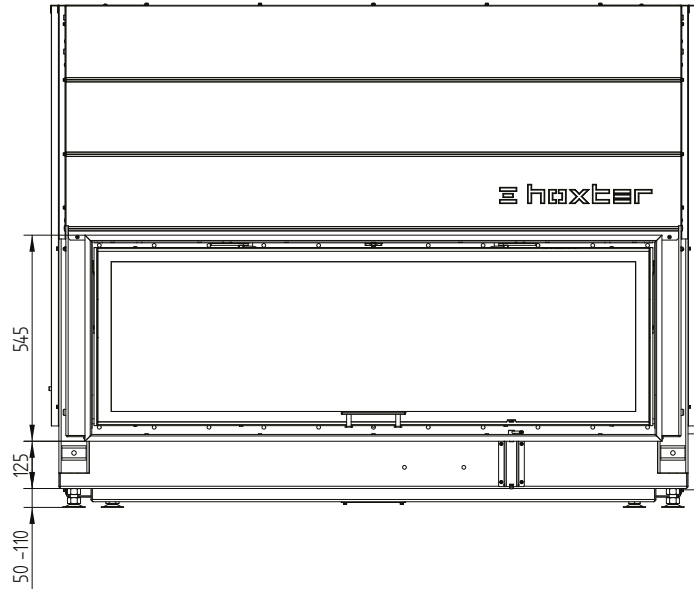
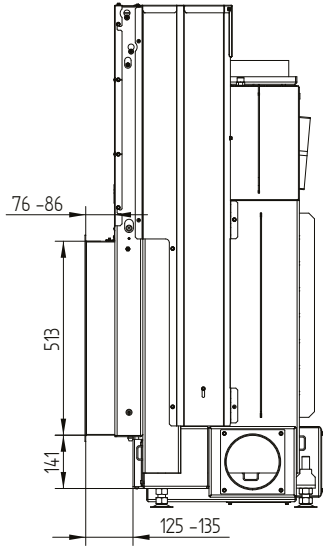

HAKA 150/51h

Technical data
Version 09/2023

Build-on frame 150/51h liftdoor 4sides 50 mm / feet

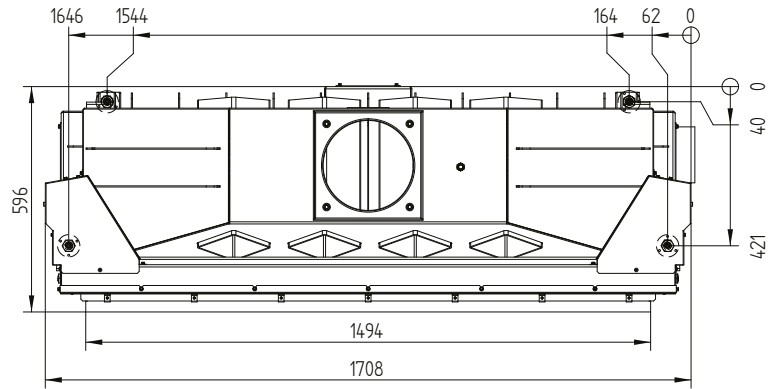
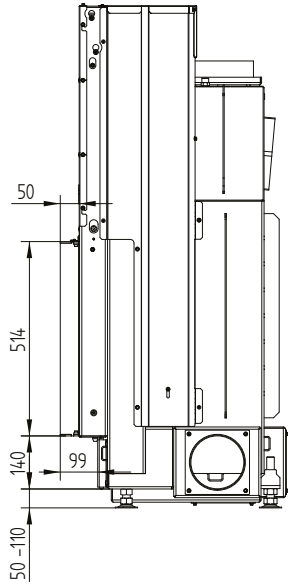

Build-on frame 150/51h liftdoor 4sides 80 mm

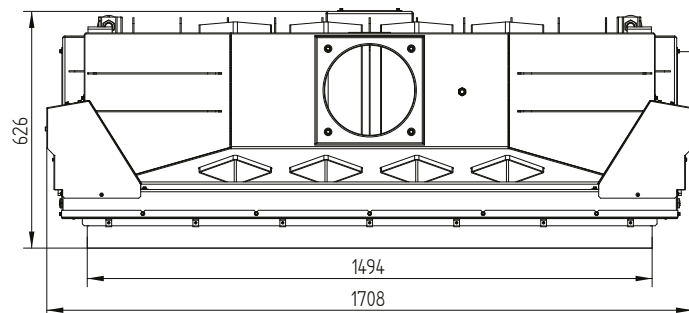
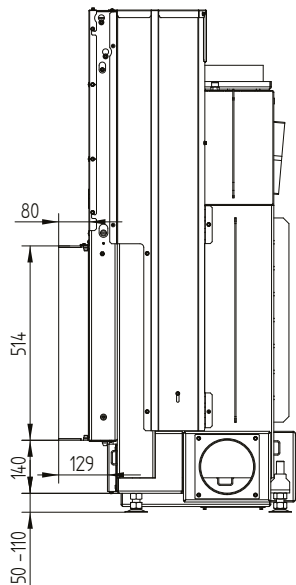

HAKA 150/51h

Technical data
Version 09/2023

Build-on frame 150/51h liftdoor 3sides 80 mm

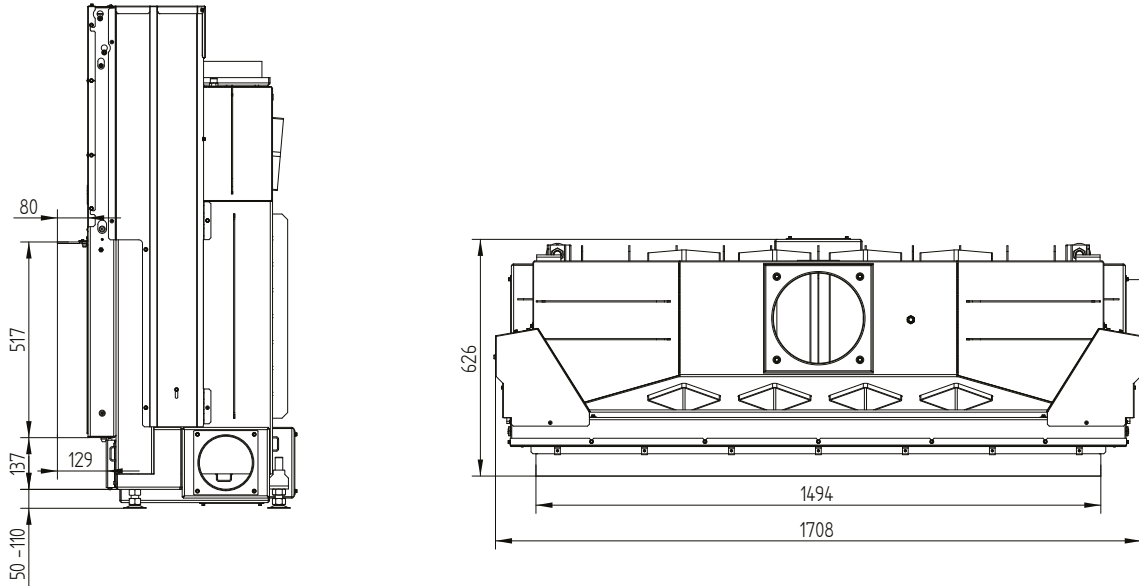

Convection jacket 150/51h liftdoor

